

Easy to install, low-maintenance and with an attractive design: The MIDI/MAXI floating fountain features for interesting water effects both day and night.

Three different motor power outputs with confirming to standards earthed plugs (230 V) and motor circuit breaker or CEE plug (400 V) offer solutions for different bodies of water and conditions. Optimised water pressure creates impressive heights for the four available nozzle patterns with 3" standard threads for fast changing. The easy-to-install LunAqua 10 LED/01 illumination set provides for impressive illumination of the water features with a height of up to 16.5 m.



**Schuko plugs + control box** The 230V version is delivered ready for operation with control box and Schuko connector.



**CEE-connector + protection switch** The 400V version comes with a ready-to-connect, 5-pole CEE connector and motor protection switch



	MIDI II 1.1 KW/230V	MAXI II 4.0 KW/400V		MIDI II 2HP/230V 60Hz	MAXI II 5HP/3-Phase
Dimensions incl. Nozzle (Ø x H) [mm]	1030x 1000	1030 x 1460	[in.]	46 x 28	46 x 38
Motor power [kW]	1.1	4.0	[W/A]	2749 / 13.2	3738 / 19.8
Pump output [l/h]	22000	39000	[l/h]		
Minimum water depth [mm]	1000	1250	[ft.]	3	4
Protection class	IP 68	IP 68		IP 68	IP 68
Rated current (230V/400V) [A]	7.3	9.6	[W/A]	2749 / 13.2	3738 / 19.8
Voltage [V/Hz]	230 AC / 50	400 AC / 50	[V/Hz]	230 / 60	208-230 / 60
Weight [kg]	43	60	[lbs]	88	132
Pump cable set (length) [m]	50	50	[ft.]	600	450
<b>Order no.</b>	<b>50365</b>	<b>50371</b>		<b>50372</b>	<b>50374</b>



	Fresh Water	Pool Water	Sea Water	220-240 V	400 V	110-120 V	50 Hz	60 Hz
MIDI II 1.1 kW / 230 V	✓	✓	✓	✓	✓	✓	✓	✓
MAXI II 4.0 kW / 400 V	✓	✓	✓	✓	✓	✓	✓	✓
MIDI II 2HP / 230 V 60 Hz	✓	✓	✓	✓	✓	✓	✓	✓
MAXI II 5HP / 3-Phase	✓	✓	✓	✓	✓	✓	✓	✓

## FLOATING FOUNTAIN MIDI II / MAXI II

### Product characteristics at a glance

- Models from 1.1 to 4.0 KW and 2 HP to 5 HP
- Complete, ready-to-connect fountain in different motor horse powers
- Four easy-change nozzle patterns with 3" standard threads
- Foamed float for extraordinary stability and minimum noise
- Stainless steel pump basket
- Mounting set included
- Optional lighting set



MIDI II 1.1 kW/230V

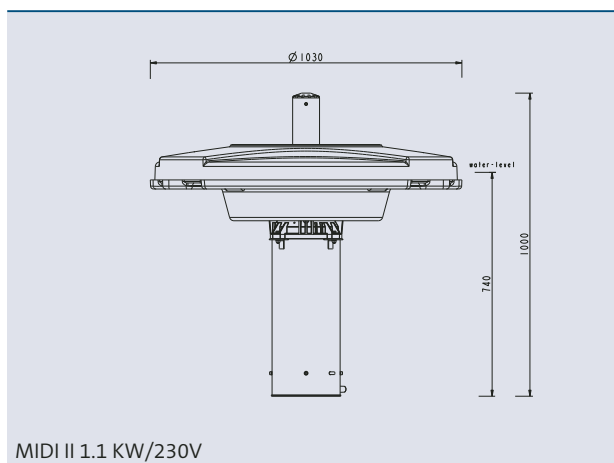

MIDI II 1.1 kW/230V

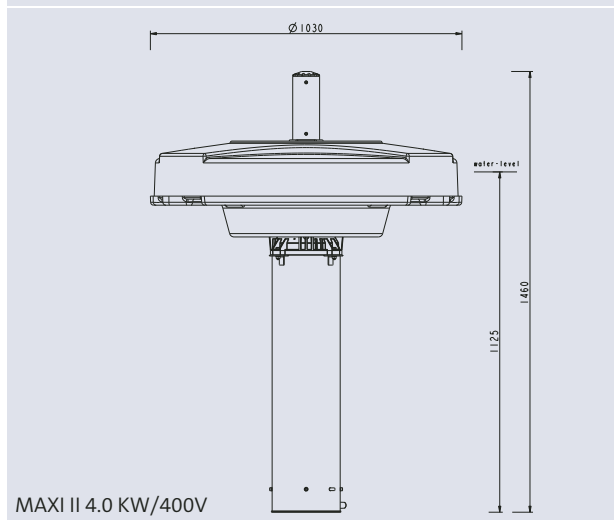

MAXI II 4.0 kW/400V